

General Specifications

Model VJTK Limit Alarm (Thermocouple Input Type)



GS 77J01T21-01E

General

This plug-in type Limit Alarm for thermocouple input receives thermocouple signal.

- Each parameter setting can be changed using a PC (VJ77 PC-based Parameters Setting Tool) or the Handy Terminal (JHT200).

Model and Suffix Codes

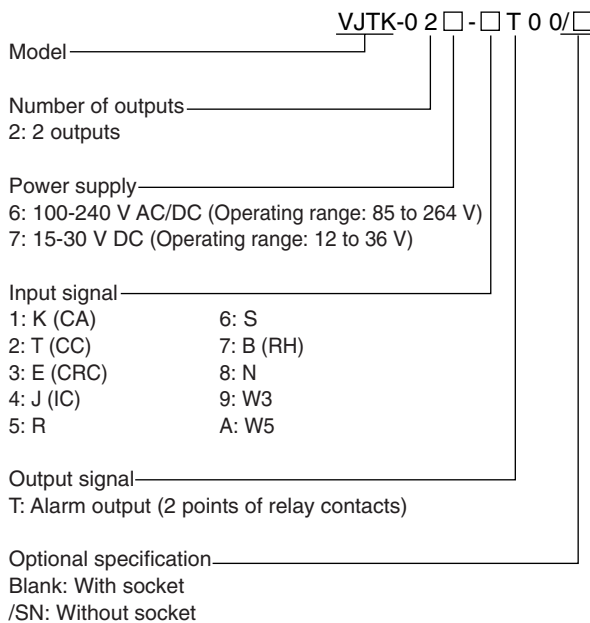

Ordering Information

Specify the model and suffix codes at the time of order. If the input range and burnout are specified with the order, the specified values will be assigned before shipment.

For other setting items, the initial values shown below are to be assigned.

- Model and suffix codes: e.g. VJTK-026-1T00
- Input range: 0 to 1000°C
- Burnout: UP

Initial Values (Factory-set Values)

The initial values (factory-set values) are as follows.

- Input range: 0 to 1000°C
- Burnout: UP
- Direction of alarm action: High-limit alarm (alarm 1), low-limit alarm (alarm 2)
- Direction of relay action: De-energized under normal condition (alarm 1 and alarm 2).

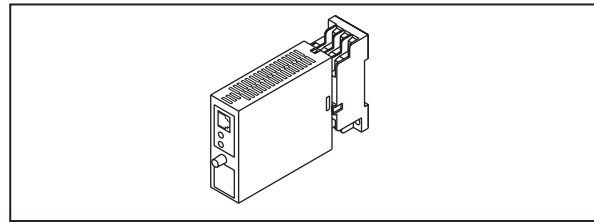

- Alarm setting: The value equivalent to 100% of input range (alarm 1), the value equivalent to 0% of input range (alarm 2)
- Hysteresis: The value equivalent to 3% of input range (alarm 1 and alarm 2)
- Alarm ON delay: 0 second (alarm 1 and alarm 2)
- Alarm OFF delay: 0 second (alarm 1 and alarm 2)

Input Specifications

Signal type: Thermocouple (ITS-90)

Type K (CA), T (CC), E (CRC), J (IC), R, S, B (RH), N, W3 (Note 1), W5 (Note 2)

Note 1: Type W3 is W97Re3-W75Re25 (tungsten 97% rhenium 3%-tungsten 75% rhenium 25%). The abbreviation of ASTM E988 Standard.

Note 2: Type W5 is W95Re5-W74Re26 (tungsten 95% rhenium 5%-tungsten 74% rhenium 26%). The abbreviation of ASTM E988 Standard.

Input range:

Input type	Guaranteed range
Type K	-200 to 1200°C
Type T	-200 to 350°C
Type E	-200 to 800°C
Type J	0 to 750°C
Type R	0 to 1600°C
Type S	0 to 1600°C
Type B	600 to 1700°C
Type N	-200 to 1200°C
Type W3	0 to 2000°C
Type W5	0 to 2000°C

Measuring span: 3 mV or more (converted into thermoelectromotive force)

Input resistance: 1 MΩ (during power on), 4 kΩ (during power off)

Burnout detective current: 0.05 μA

Allowable leadwire resistance: 500 Ω or less

However, when used with BARD-600, this value can be added to the BARD internal resistance.

Maximum allowable voltage: ±4 V DC

■ Output Specifications

- Signal type: Relay contact
 Output signal: NO contact output (contact turns on when energized), 2 points
 Contact rating: 120 V AC/1 A, 220 V AC/0.5 A (resistance load); 30 V DC/1 A, 120 V DC/0.1 A (resistance load)
 Direction of alarm action: High-limit alarm or low-limit alarm
 Direction of relay action: Energized or de-energized under normal condition
 Alarm setting range: 0 to 100% of input range
 Setting resolution: 0.1°C, with four significant digits
 Hysteresis setting range: 0 to 100% of input range
 Setting resolution: 0.1°C, with four significant digits
 Alarm ON delay: Condition monitoring time from the establishment of alarm conditions to its output. (For example, when an alarm ON delay is set to 1 second, alarm output is generated if alarm status continues for 1 second or more after the input value exceeds the alarm setpoint.)
 Setting range: 0 to 999 seconds
 Setting resolution: 1 second (However, about 0.2 second is to be added to the set time to prevent wrong operation.)
 Alarm OFF delay: Condition monitoring time from the establishment of return-to-normal conditions to its output.
 (For example, when an alarm OFF delay is set to 2 seconds, alarm output is released if normal condition continues for 2 seconds or more after the input value has returned to normal from the alarm status.)
 Setting range: 0 to 999 seconds
 Setting resolution: 1 second (However, about 0.2 second is to be added to the set time to prevent wrong operation.)
 Indication of alarm action: The alarm indicator lamp (LED) on the front panel lights up if an alarm occurs. (2 lamps)

■ Items Available to Be Set

The following items can be set using a PC (VJ77 PC-based Parameters Setting Tool) or the Handy Terminal (JHT200):

- Input type, input range, burnout, direction of alarm action, direction of relay action, alarm setting, hysteresis, alarm ON delay and alarm OFF delay

■ Standard Performance

- Accuracy rating: $\pm 0.1\%$ of span
 However, the accuracy is limited in the following cases.
 When a span is less than 27.5 mV in an input range of -10 to 100 mV (M range) converted into thermoelectromotive force:

$$\text{Accuracy (\%)} = \pm 0.1 (\%) \times 27.5 (\text{mV}) / \text{input span (mV)}$$

 When a span is less than 10 mV in an input range of -2.5 to 25 mV (L range) converted into thermoelectromotive force:

$$\text{Accuracy (\%)} = \pm 0.1 (\%) \times 10 (\text{mV}) / \text{input span (mV)}$$

- Reference junction compensation accuracy:
 $\pm 1^\circ\text{C}$ (other than Type R and S); $\pm 2^\circ\text{C}$ (Type R and S) at $25^\circ\text{C} \pm 15^\circ\text{C}$
 Response speed: 450 ms (Time to alarm output when the input change is 10 to 90% and alarm setpoint is 50%. When the alarm delay setting and hysteresis are minimum.)
 Burnout: UP, DOWN or OFF
 Burnout time: Within 60 seconds
 Effect of power supply voltage fluctuations: $\pm 0.1\%$ of span or less for the fluctuations within the allowable range of each power supply voltage specification
 Effect of ambient temperature change: $\pm 0.2\%$ of span or less for a temperature change of 10°C
 Effects of leadwire resistance change: $\pm 15 \mu\text{V}$ or less for a change of 100 Ω

■ Power Supply and Isolation

- Power supply rated voltage:
 100-240 V AC/DC \approx 50/60 Hz or
 15-30 V DC \approx
 Power supply input voltage: 100-240 V AC/DC \approx (-15, +10%) 50/60 Hz or
 15-30 V DC \approx ($\pm 20\%$)
 Power consumption: 24 V DC 1.9 W, 110 V DC 1.9 W
 100 V AC 4.1 VA, 200 V AC 5.1 VA
 Insulation resistance: 100 M Ω /500 V DC between input, output 1, output 2, power supply and grounding terminals mutually.
 Withstand voltage: 2000 V AC/minute between input, (output 1, output 2), power supply and grounding terminals mutually.
 1000 V AC/minute between output 1 and output 2 terminals.

■ Environmental Conditions

- Operating temperature range: 0 to 50°C
 Operating humidity range: 5 to 90% RH (no condensation)
 Operating conditions: Avoid installation in such environments as corrosive gas like sulfide hydrogen, dust, sea breeze and direct sunlight.
 Installation altitude: 2000 m or less above sea level.

■ Mounting and Dimensions

- Construction: Compact plug-in type
 Material: Modified polyphenylene oxide resin (casing)
 Mounting method: Wall or DIN rail mounting, or mounting using VJ mounting base
 Connection method: M3 screw terminal
 External dimensions: 29.5 (W) \times 76 (H) \times 124.5 (D) mm (including a socket)
 Weight: Approx. 170 g

■ Accessories

- Tag number label: 1 sheet
 Range label: 1 sheet
 RJC sensor: 1

Terminal Assignments

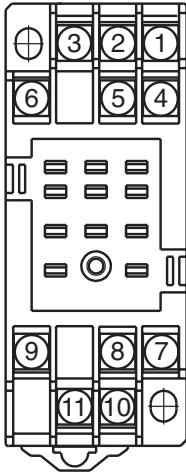

Terminal No.	Signal
1	Input (+)
2	Alarm 2 (NO)
3	Input (-) RJC
4	Input (Reverse side of RJC)
5	Alarm 2 (COM)
6	N.C.
7	Alarm 1 (NO)
8	Ground (GND)
9	Alarm 1 (COM)
10	Supply (L+)
11	Supply (N-)

Block Diagram

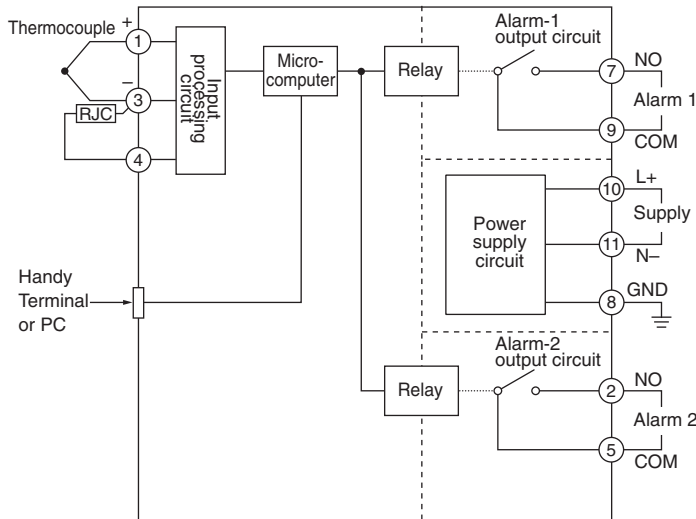

External Dimensions

